

Motorcycle safety fixing support

At motorcycle brake measurements on passenger car roller brake testers the unit helps the longitudinal fixing and provides lateral support.



- Quick and easy installation
- Fixing by chain to prevent the motion of the unit
- Equipped with anti-slip rubber
- Fixing of the wheel by manual screw spindle

Requirements for installation

- Fixing the chain holders on the floor

Standard equipment

- Mechanical unit with fixing vice
- Chains in length of 2m, with chain holders (2 pcs)
- Fixing screws (4 pcs)

Optional accessories

- Motorcycle adapter (**MFSZ**)
- Energoline® brake measurement module for motorcycles

Technical data

Wheel diameter for fixing:	300 - 800 mm
Maximum wheel width:	184 mm
Maximum wheelbase:	2000 mm

Actuation:	manual
Corrosion protection:	galvanised



MBT in use

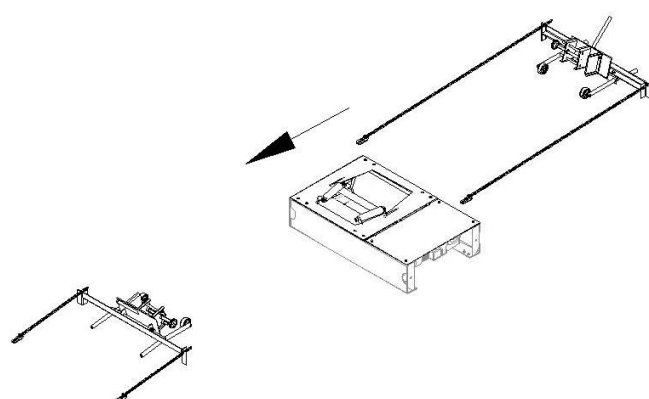

Installation scheme

Notes:

Made in Hungary

Your Partner:

Due to constant product improvement Energotest reserves the right to make changes without prior notice. Images may contain optional extras.

www.energotest.eu

✉ H - 2330 Dunaharaszti, Gomba u. 4.
Hungary

☎ +36-24 / 50-11-50 Fax +36-24 / 50-11-70

Technical information: tms@energotest.hu
Sales: export@energotest.hu

Company reg. no.:

13-09-075580

